

Responsibility of each layer

Layer	Responsibility	IEEE 1394 specific topics
Application Layer		Direct printing, PC-printing Status monitoring, Power Management
Presentation Layer	application specific service	bit image data format data structure for session
Session Layer	multiple host service error recovery	login/logout control
Transport Layer	flow control, multiple logical channel error detection	
Network Layer	device specific transaction	Reconnection after bus rest
Data Link Layer	device specific connectivity	Node ID detection

EPSON

What is minimal requirement for PC printing protocol (1)

- **Multiple Logical Channel**

IEEE 1284.4 is convenient,...

- **Flow Control**

Pull style flow control has better performance in IEEE 1394 platform. From this point of view SBP-2 is suitable.

- **Multiple Hosts Connectivity**

Printer requests hosts to login.

- **Multiple Targets Connectivity**

Hosts request printers to have self identification.

- **Reconnection after bus reset**

IEEE 1394 specific issue. Thus transport layer shall not be responsible for this requirement.

EPSON

September 15th -16th 1997

What is minimal requirement for PC printing protocol (2)

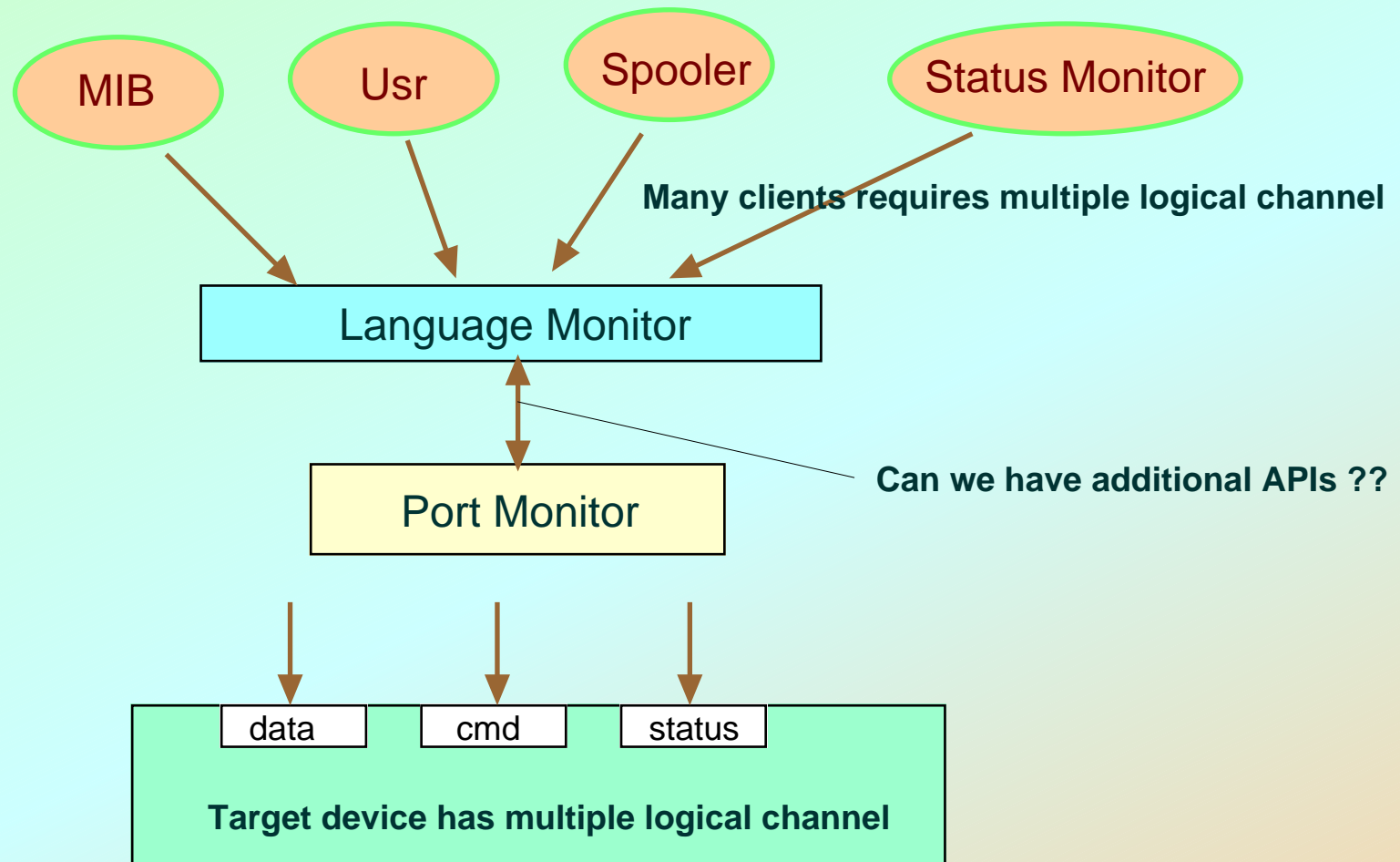

EPSON

September 15th -16th 1997

Old Epson Model had complexity (1)

An example shows complicated protocol stack

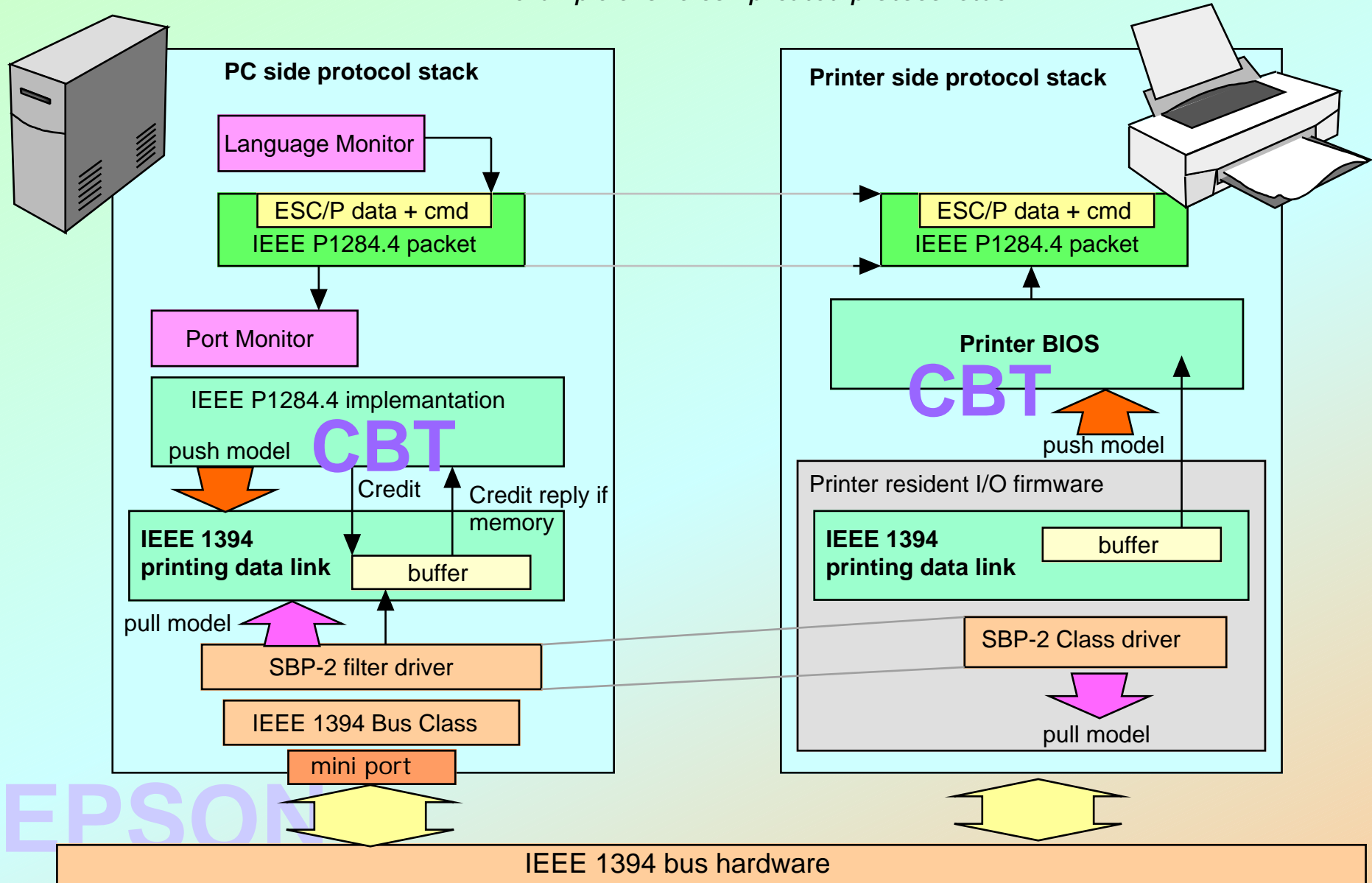

Old Epson Model had complexity (2)

"Push --> Pull conversion" brings complexity
"Push --> Pull conversion" requires pseudo buffering

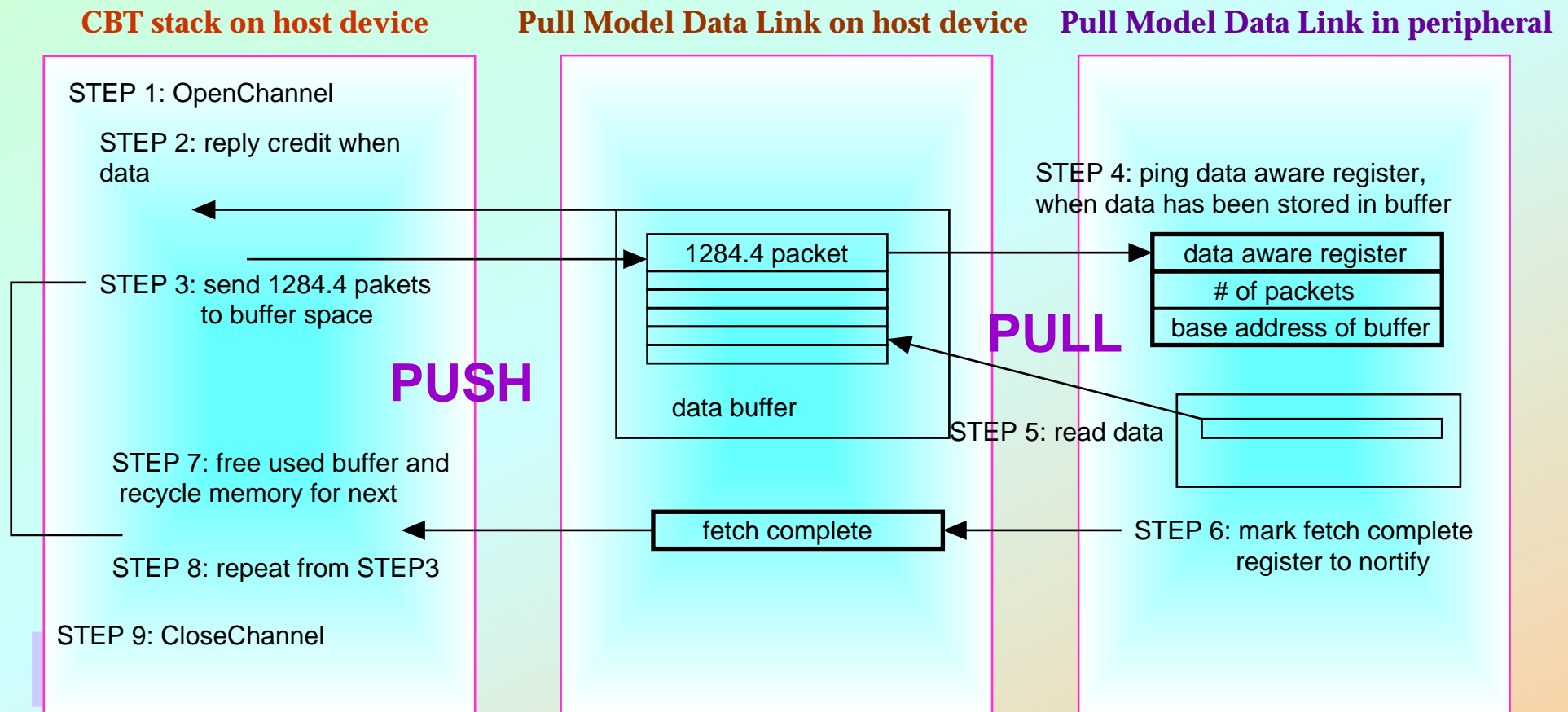

Improved Epson Model resolved complexity

Improved protocol stack gives simple memory bus architecture

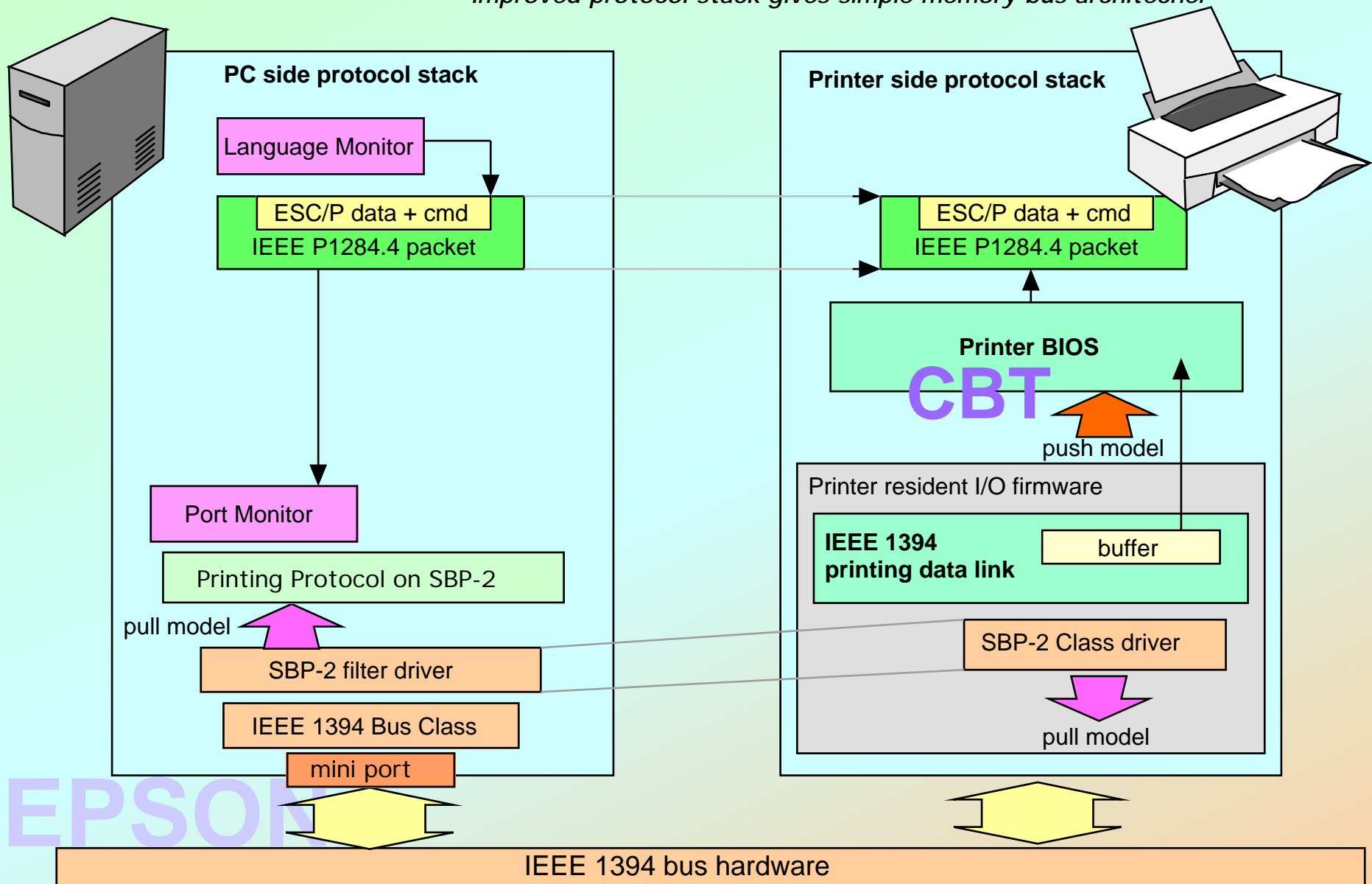

Improved Epson Model resolved complexity

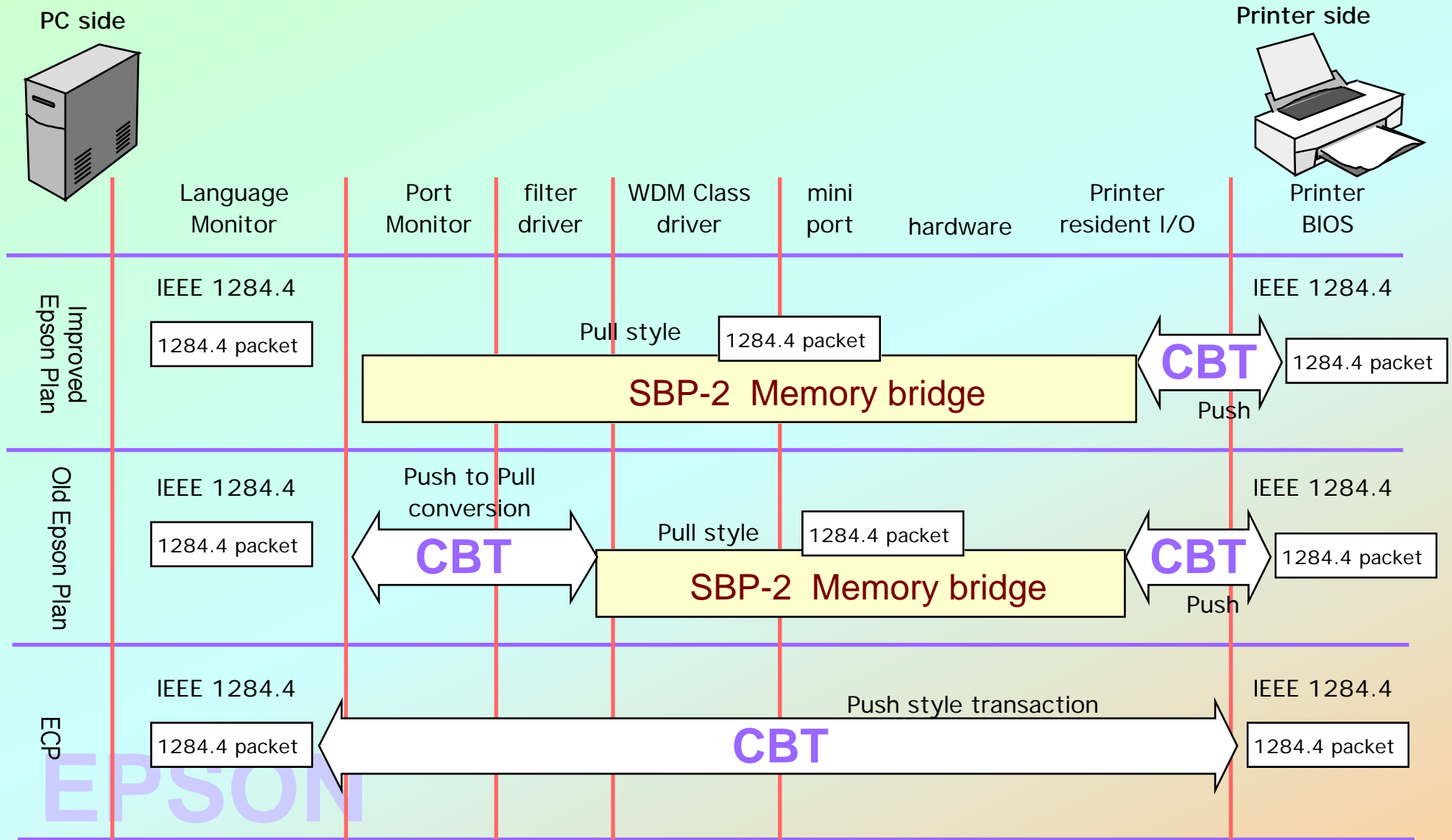

Gap between implementation and specification (1)

- Implementation of multiple logical channel through SBP-2
 - How many logins does one printing session require ?

- **Build multiple logical channel internally with in one login**

SBP-2 has multiple channel capability. However SBP-2 driver requires 1284.4 packets to be unpacked and re-assigned to SBP-2 logical channel.

- **Requires multiple login as same as number of the logical channel**

Smart and simple. But this way does not give any answer for login race condition from many hosts.

- **Prioritized logins**

Primary login negotiate data session, then secondary login starts data session (printing). Epson proposal Rev. 0.4 chose this way.

EPSON

Gap between implementation and specification (2)

- Keep connectivity even if printer has some trouble while printing

A0 size plotter application requires more than 720 dpi resolution with full color. Printing requires more than one hour.

- **Functionalty provided by Epson Protocol**

- **Conditions for printer to be considered unresponsive**
- **Conditions for host to be considerd unresponsive**
- **Tickle packets exchange between target and initiator**

EPSON

September 15th -16th 1997

Design feature of Epson Protocol (1)

- Guarded data session associated with two logins

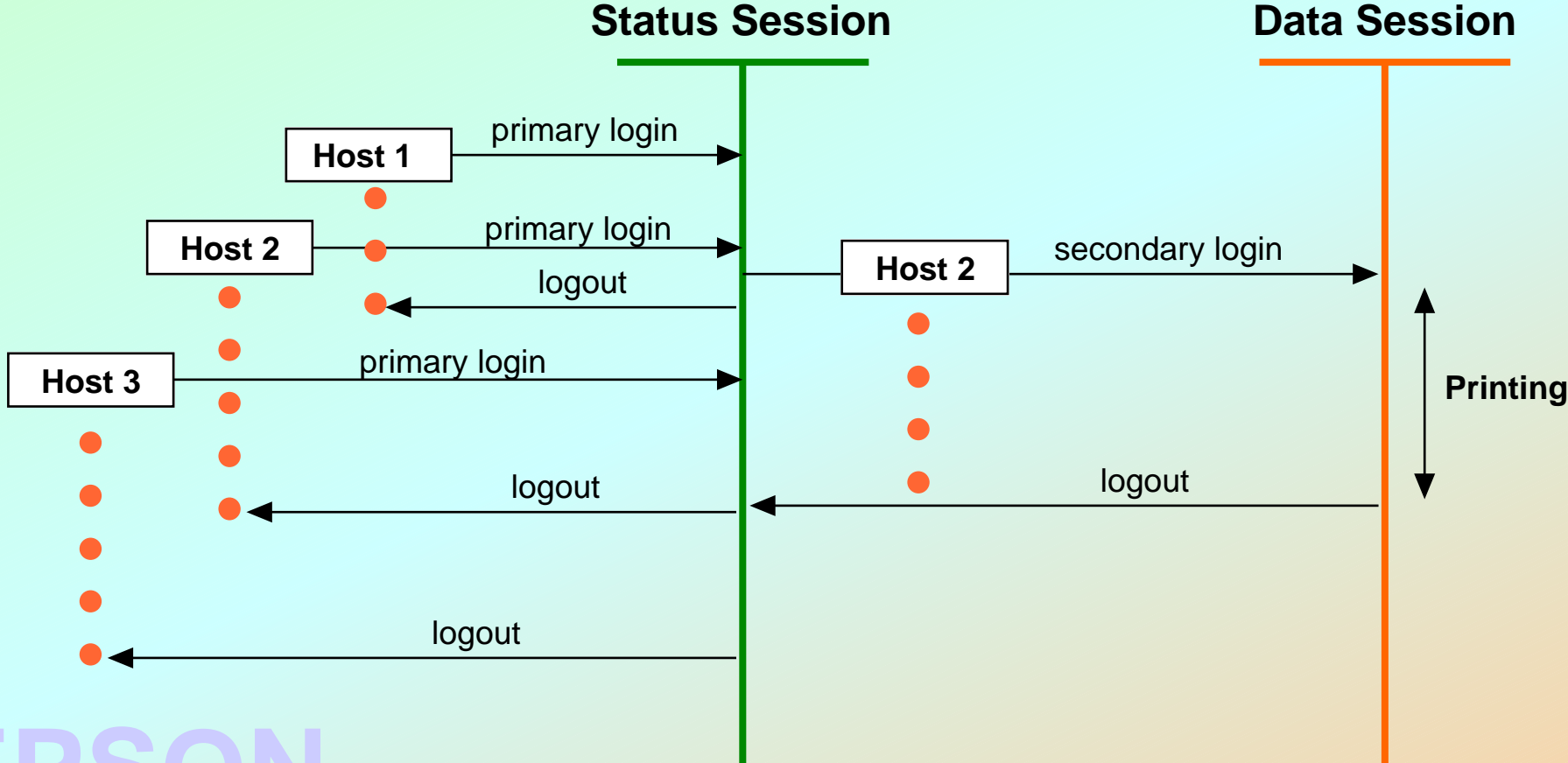

Design feature of Epson Protocol (2)

- **Prioritized request manipulation**

Status Session has higher execution priority

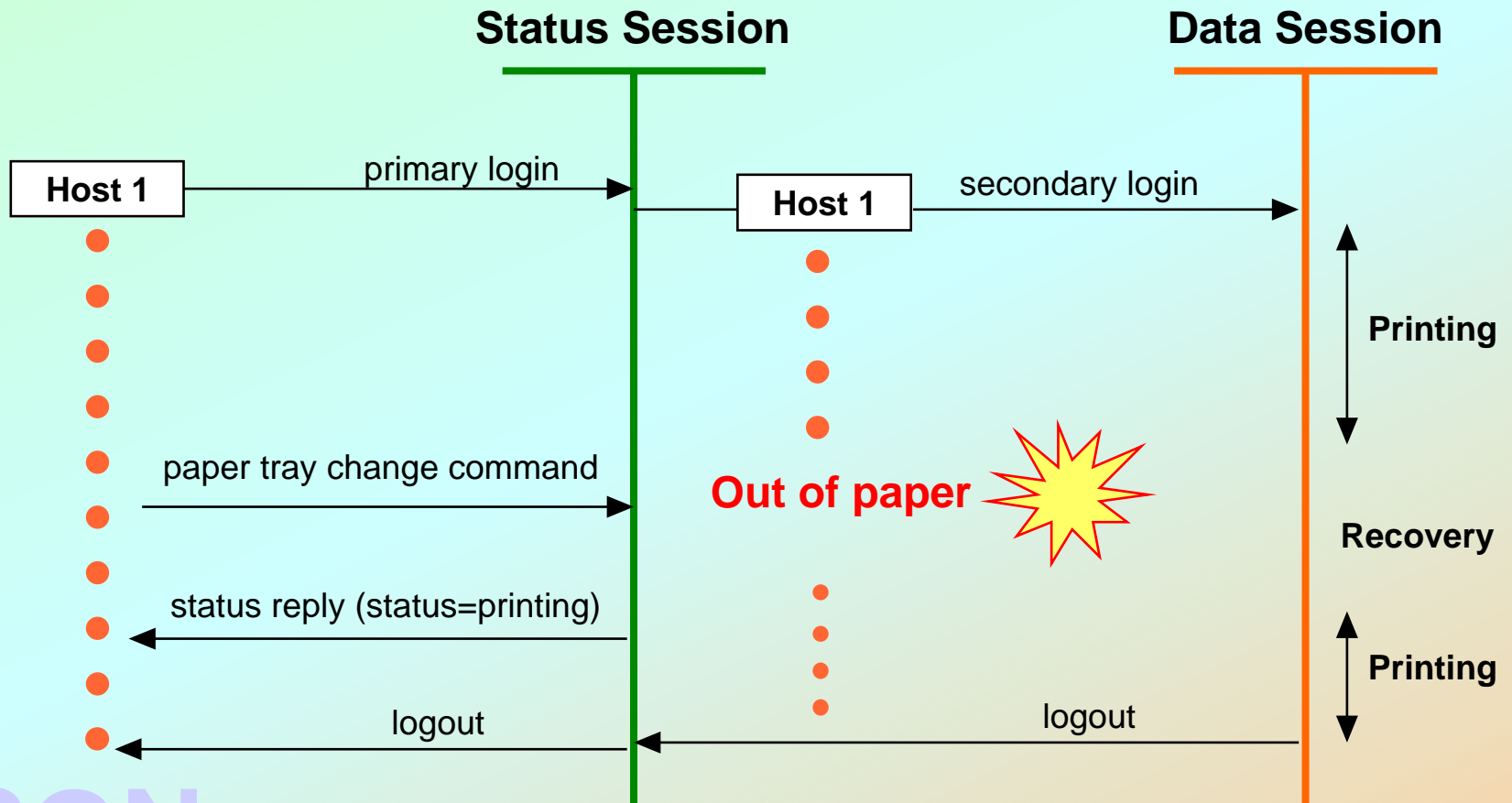

EPSON

Design feature of Epson Protocol (3)

- Solicitation after race condition for logins

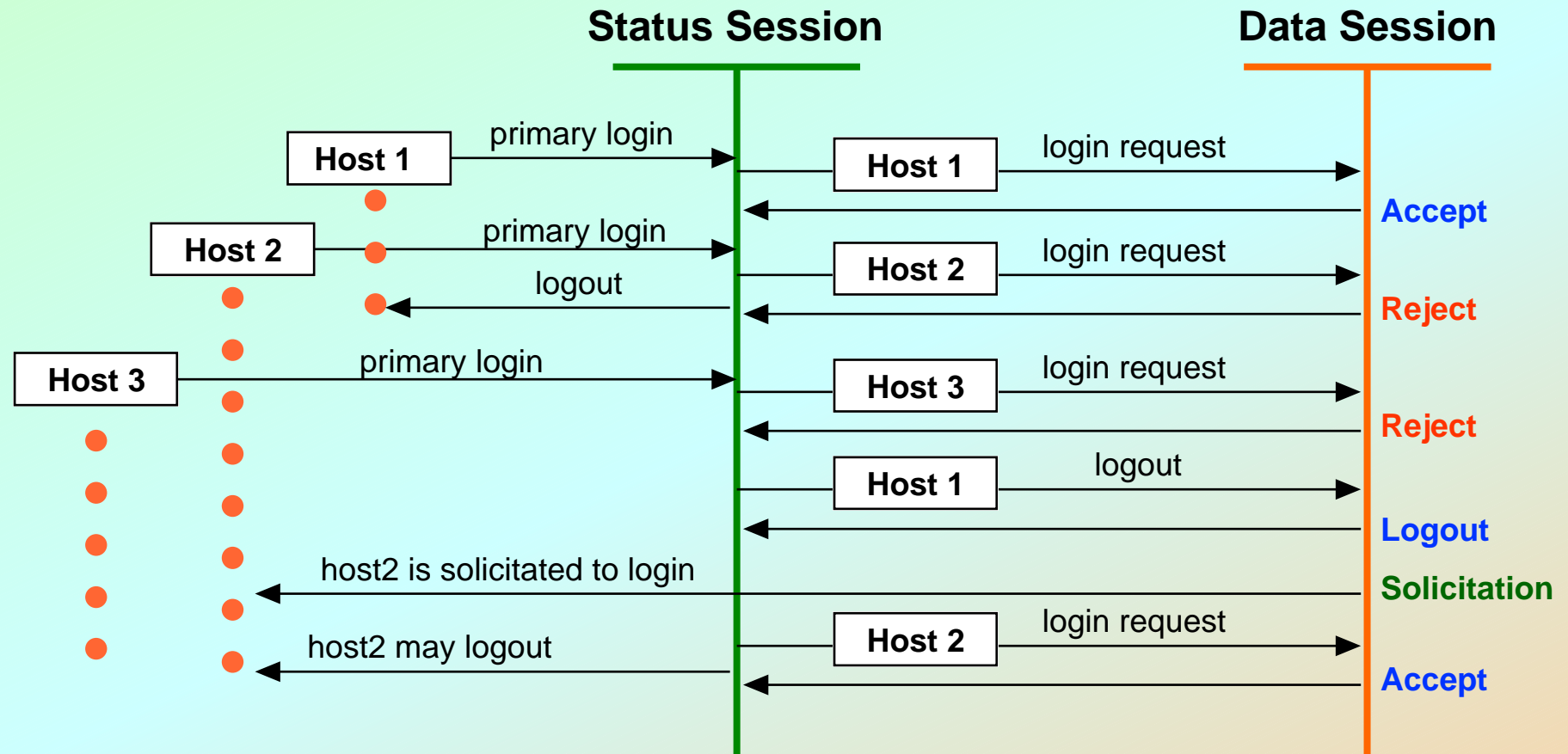

EPSON

SBP-2 is not abstracted from Data Link Layer

	IEEE 1284.4	SBP-2
<ul style="list-style-type: none"> • Multiple Hosts Connectivity • Multiple Targets Connectivity <p>Session Layer</p>	<p>×</p> <p>×</p>	<p>○</p> <p>○</p>
<ul style="list-style-type: none"> • Multiple Logical Channel • Flow Control <p>Transport Layer</p>	<p>○</p> <p>○</p>	<p>○</p> <p>○</p>
<ul style="list-style-type: none"> • Reconnection after bus reset <p>Network Layer</p>	<p>×</p>	<p>○</p>



***if you have opinion
please contact to,.....***

Fumio.Nagasaka@exc.epson.co.jp

EPSON

September 15th -16th 1997

Thank you !

EPSON

September 15th -16th 1997